

REV	EC No.	DESCRIPTION	Symbol	DATE
A	/	new release	/	Mar. 12, 2018

- MATERIAL SPECIFICATION:
  - HOUSING: HIGH TEMPERATURE RESISTANT PLASTIC, UL94 V-0.
  - CONTACTS: COPPER ALLOY
  - MID PLATE: STAINLESS STEEL
  - FRONT SHELL: STAINLESS STEEL
- MECHANICAL PERFORMANCE,
  - INSERTION FORCE: 5~20N.
  - REMOVAL FORCE: 6~20N.
  - DURABILITY: 10000 CYCLES.
- ELECTRICAL PERFORMANCE,
  - CURRENT RATING: 3.0A  
VOLTAGE RATING: 12V
  - LLCR:  
VBUS & GND PINS AND OTHER PINS: 40mΩ/PIN MAX.  
SHIELD: 50mΩ/MAX.
  - INSULATION RESISTANCE: 100MΩ MIN
  - DIELECTRIC WITHSTAND VOLTAGE, AC 100V FOR 1 MINUTE.
- ENVIRONMENTAL PERFORMANCE:
  - OPERATING TEMPERATURE: -40°C~+85°C.
- PACKAGE: TAPE REEL, 1000PCS/REEL

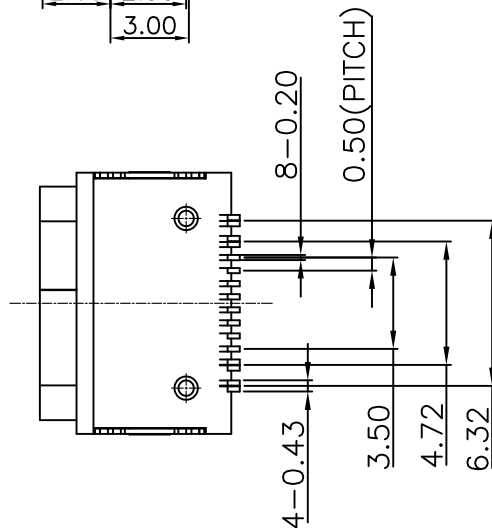
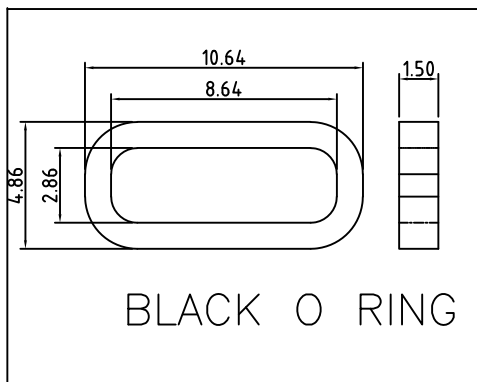
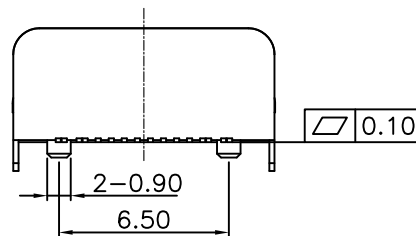
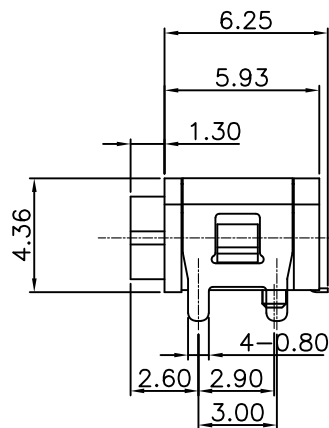
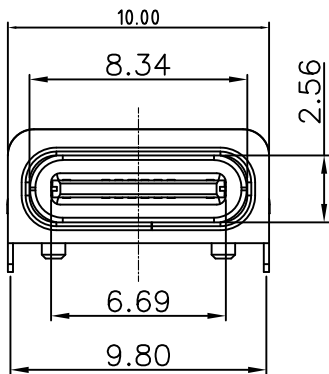
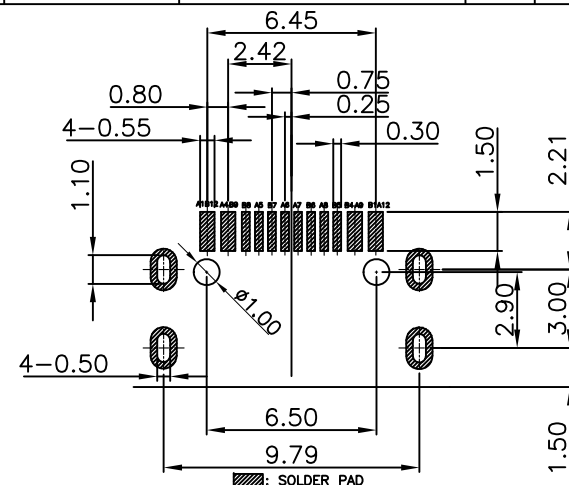

NO.	DESCRIPTION	MATERIAL	REMARKS	QTY
6	O RING	SILICON	BLACK	1PCS
5	SHELL	STAINLESS STEEL	NI Plated	1PCS
4	SHIELDING PLATE	STAINLESS STEEL	NI Plated	1PCS
3	CONTACT	COPPER ALLOY	Au/Ni Plated	1SET
2	SHELL HOUSING	HIGH TEMPERATURE PLASTIC	BLACK	1PCS
1	HOUSING	HIGH TEMPERATURE PLASTIC	BLACK	1PCS

For more information, please feel free to contact Neal. His email is :connmold@foxmail.com Tel:18922965797

WWW.CONNMOLD.COM		<h1>ConnMold</h1>	
DIMENSION UNITS	TOLERANCE		
MM	X±0.50 .XX±0.25 .X±0.35 .XXX±0.15	PART NAME	USB TYPE C 16PIN 4.36MM WATERPROOF IP66
DRWN:Robert	Mar. 12, 2018	PART NUMBER	CMWUC661006
CHK'D:Yuri	Mar. 12, 2018	REVISION	A
APPR:Lee	Mar. 12, 2018	CUSTOMER	GENERAL MARKET
THIRD ANGLE PROJECTION	CUSTOMER P/N	SHEET NUMBER	1 OF 2
	/		