

REV	EC No.	DESCRIPTION	Symbol	DATE
A	/	new release	/	Mar. 12, 2018

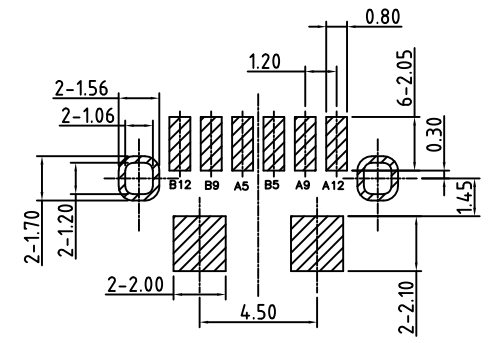

THICKNESS T=1.0mm  
TOLERANCE:±0.05

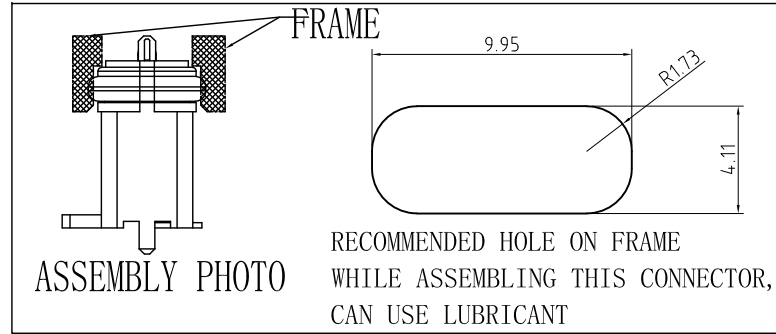
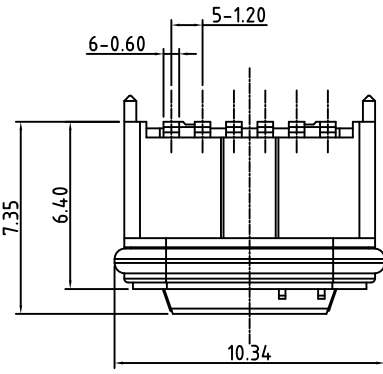
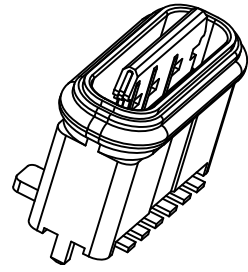
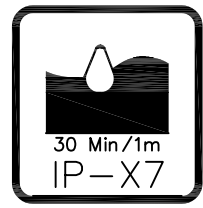
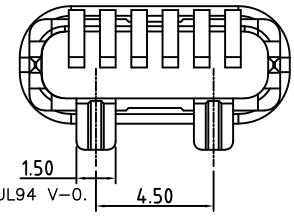
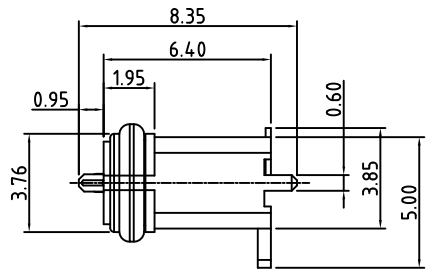
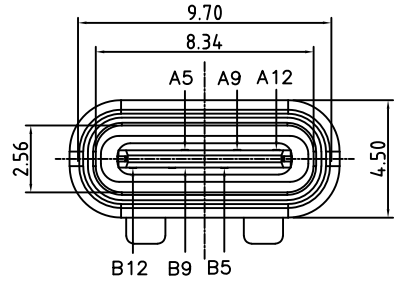

A5	CC1	B12	GND
A9	VBUS	B9	VBUS
A12	GND	B5	CC2
PIN	SIGNAL NAME	PIN	SIGNAL NAME

- MATERIAL SPECIFICATION:
  - HOUSING: HIGH TEMPERATURE RESISTANT PLASTIC, UL94 V-0.
  - CONTACTS: COPPER ALLOY
  - SHELL: STAINLESS STEEL
- MECHANICAL PERFORMANCE,
  - INSERTION FORCE: 5~20N.
  - REMOVAL FORCE: 6~20N.
  - DURABILITY: 10000 CYCLES.
- ELECTRICAL PERFORMANCE,
  - CURRENT RATING: 3.0A  
VOLTAGE RATING: 12V
  - LLCR:  
VBUS & GND PINS AND OTHER PINS: 40mΩ/PIN MAX.  
SHIELD: 50mΩ/MAX.
  - INSULATION RESISTANCE: 100MΩ MIN
  - DIELECTRIC WITHSTAND VOLTAGE, AC 100V FOR 1 MINUTE.
- ENVIRONMENTAL PERFORMANCE:
  - OPERATING TEMPERATURE: -40°C~+85°C.
  - PACKAGE: TAPE REEL, 500PCS/REEL

3	Shell	1	Ni Plating
2	Contact	6	Phosphor bronze Au/Ni Plating T=0.20mm
1	Housing	1	PA10T (G.F30%)
ITEM	PART NAME	Q' TY	FINISH

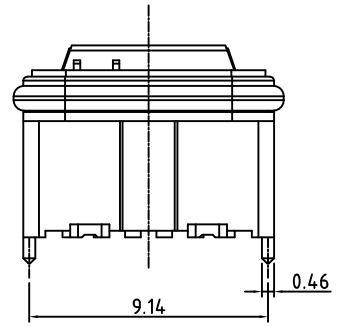

WHITE O RING  
O RING IS ASSEMBLED ON CONNECTOR BEFORE SHIPMENT

For more information, please feel free to contact Neal. His email is :connmold@foxmail.com Tel:18922965797

WWW.CONNMOLD.COM

DIMENSION UNITS	TOLERANCE	<h1>ConnMold</h1>	
MM	X±0.50 .XX±0.25 .X±0.35 .XXX±0.15		
DRWN:Robert	Mar. 12, 2018	PART NAME <b>USB TYPE C 6PIN VERTICLE 7.35MM WATERPROOF IP67</b>	
CHK'D:Yuri	Mar. 12, 2018	PART NUMBER <b>CMWUC661009</b>	
APPR:Lee	Mar. 12, 2018	REVISION <b>A</b>	
THIRD ANGLE PROJECTION	CUSTOMER P/N	CUSTOMER	SHEET NUMBER
	/	GENERAL MARKET	1 OF 2