

6 5 4 3 2 1

REV	EC No.	DESCRIPTION	Symbol	DATE
A	/	new release	/	Jan. 12, 2021

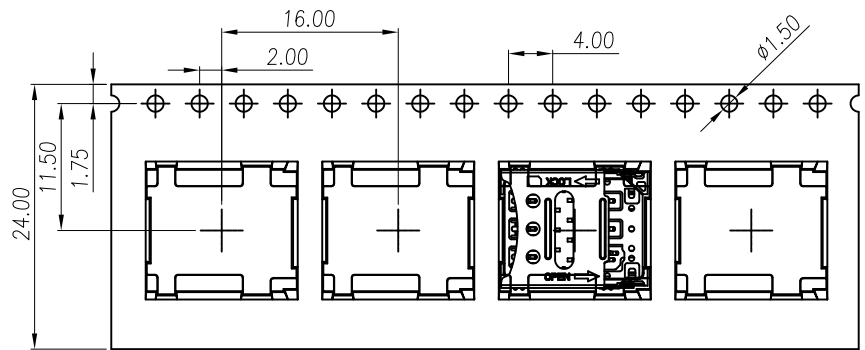
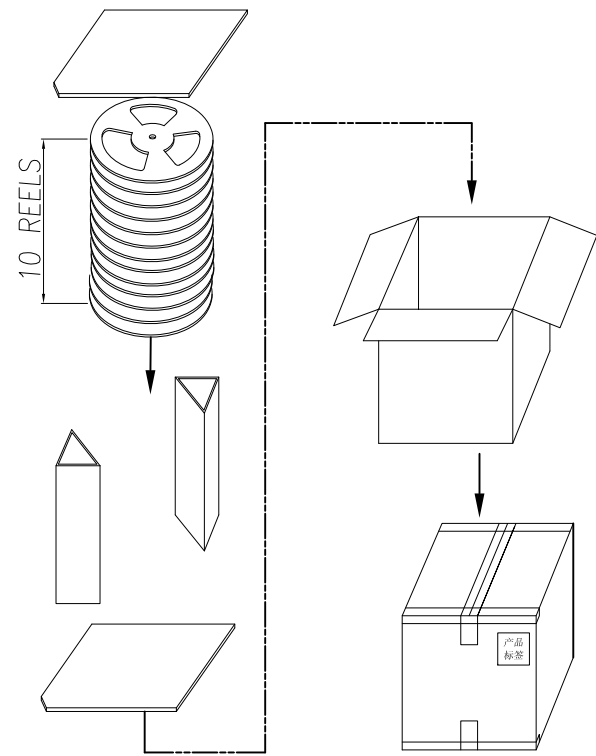
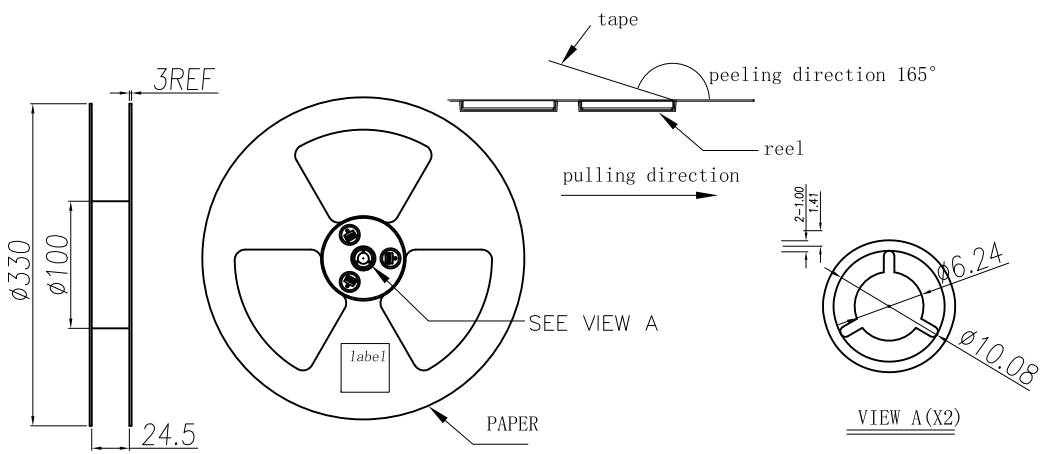

PULL OUT DIRECTION →

6 5 4 3 2 1

For more information, please help to contact: connmold@foxmail.com, Tel.: 18922965797				
WWW.CONNMOLD.COM		<h1>ConnMold</h1>		
DIMENSION UNITS	TOLERANCE			
MM	X±0.50 .XX±0.25 .X±0.35 .XXX±0.15	PART NAME NANO SIM FLIP TYPE TYPE 1.35MM HEIGHT		
DRWN: Robert	jan. 12, 2021	PART NUMBER		REVISION
CHK'D: Yuri	jan. 12, 2021	CMNSM661001		A
APPR: Linda	jan. 12, 2021	CUSTOMER		SHEET NUMBER
THIRD ANGLE PROJECTION	CUSTOMER P/N	GENERAL MARKET		2 OF 2
	/			

D
C
B
A