

6

5

4

3

2

1



REV	EC No.	DESCRIPTION	Symbol	DATE
A	/	new release	/	Mar. 12, 2018

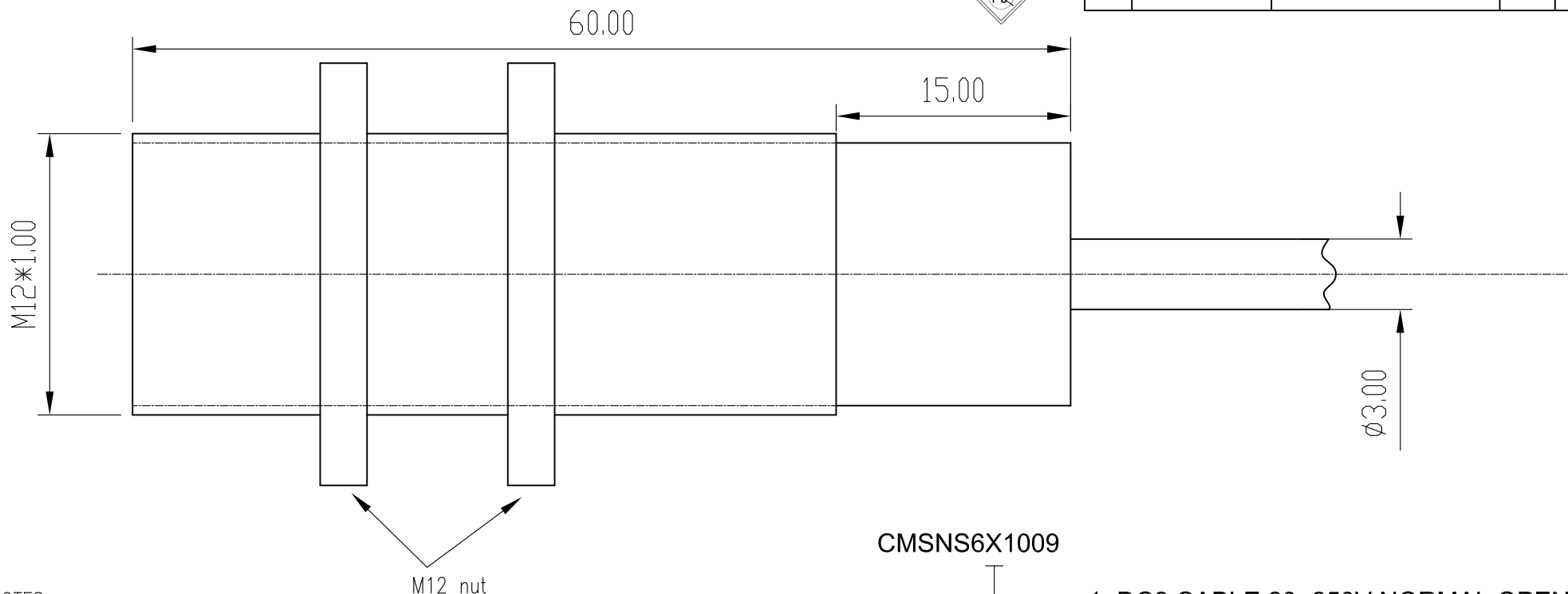

NOTES :

- | | |
|---|--|
| <p>1.0. Spec.:M12</p> <p>2.0. Metal cover housing: yes, totally</p> <p>3.0. Sensor detect distance: 2.00mm</p> <p>4.0. Shell Material:Stainless steel</p> <p>5.0. Operation Voltage:20~250V DC</p> <p>6.0. Unload current: 2.5 mA max</p> <p>7.0. Type: see part number</p> <p>8.0. Load Current: 5mA~100mA</p> <p>9.0. Leakage current:2.5mA max</p> <p>10.0 Voltage drop: 8.0V DC</p> | <p>11.0 Frequency: 40 HZ</p> <p>12.0 Response time: 10ms/10ms</p> <p>13.0 Power On/Off delay: 15% (Sr) max</p> <p>14.0 Repeat accuracy: 1.0% (Sr) max</p> <p>15.0 Waterproof grade: IP67</p> <p>16.0 Temperature Range: -25°C~+70°C</p> <p>17.0 Temperature change: 10% (Sr) Max</p> <p>18.0 Short protection: NO</p> <p>19.0 Peak current: 2.2A 20ms</p> <p>20.0 Contact surface material:POM</p> |
|---|--|

CMSNS6X1009

- 1: DC2 CABLE 20~250V NORMAL OPEN
- 2: DC2 CABLE 20~250V NORMAL CLOSE

For more information, please feel free to contact Neal. His email is :connmold@foxmail.com Tel:18922965797

DIMENSION UNITS		TOLERANCE		PART NAME	
MM		X±0.50	.XX±0.25		
		.X±0.35	.XXX±0.15		
DRWN:Robert		Mar. 12, 2018		PART NUMBER	
CHK'D:Yuri		Mar. 12, 2018		CMSNS6X1009	
APPR:Lee		Mar. 12, 2018		REVISION	
THIRD ANGLE PROJECTION		CUSTOMER P/N		GENERAL MARKET	
		/		SHEET NUMBER	
				1 OF 1	

6

5

4

3

2

1