

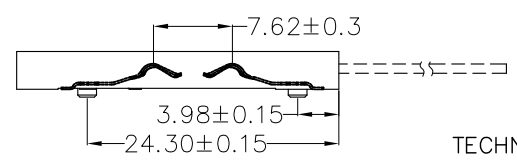

REV	EC No.	DESCRIPTION	Symbol	DATE
A	/	new release	/	Dec. 12, 2020

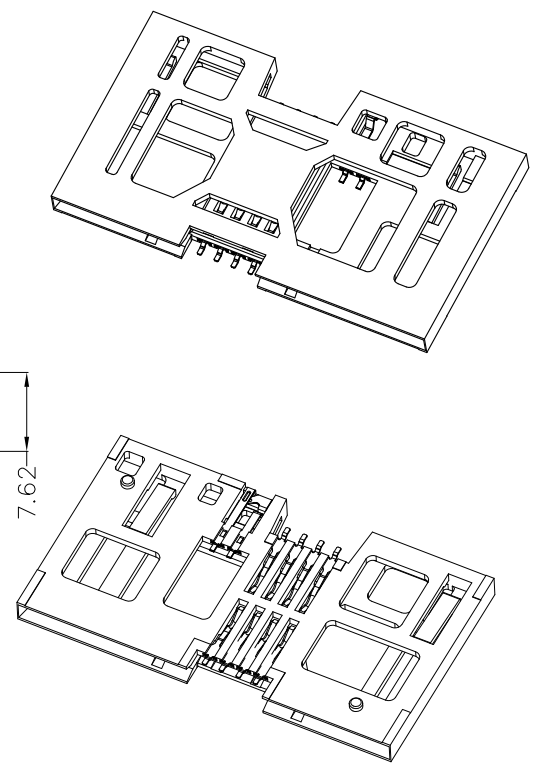
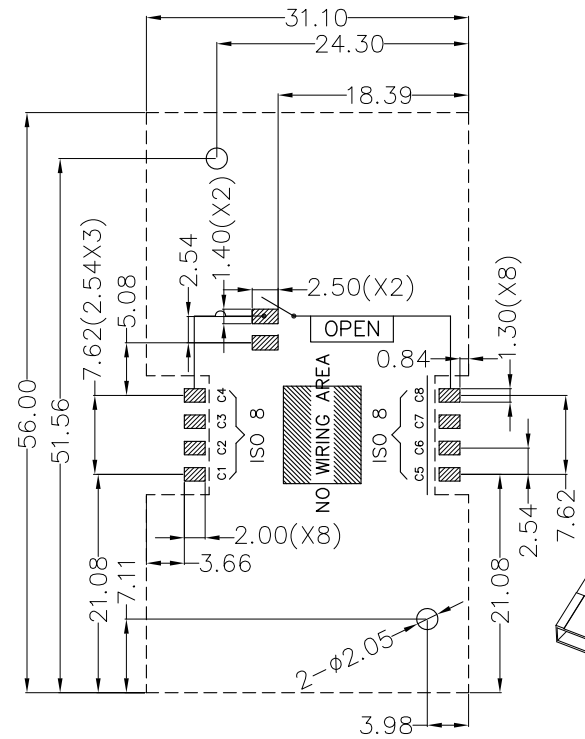
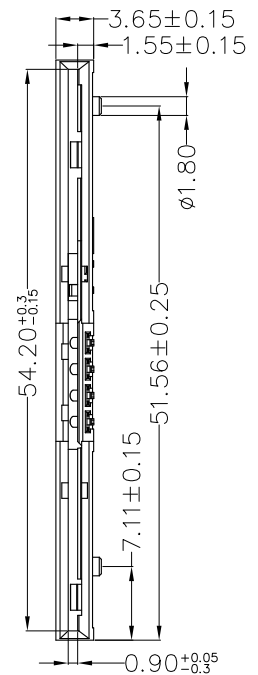
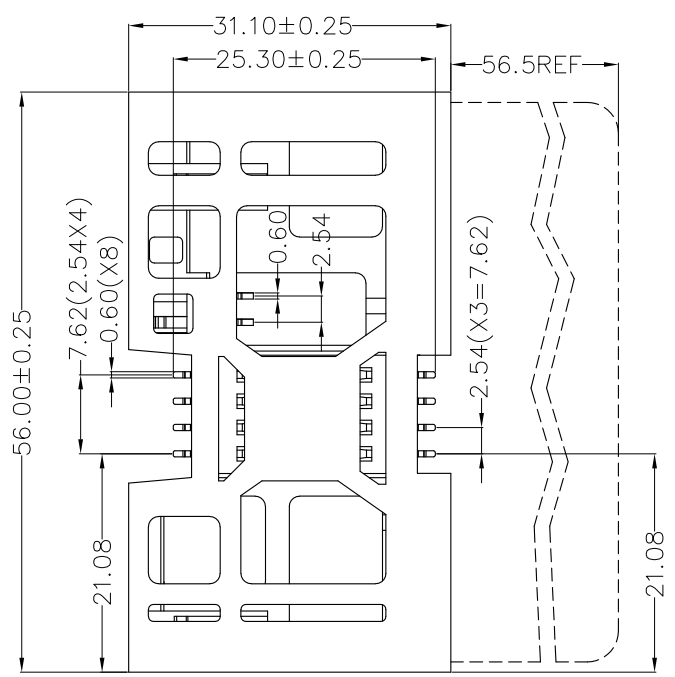

RECOMMENDED P.C.B LAYOUT
COMPONENT SIDE(TOLERANCE ±0.05)

TECHNICAL CHARACTERISTICS

- General Characteristics
 Dimensions: 56.0LX31.1Wx3.65H mm
 Weight: Approx 4.15±0.5g
 Durability: 100,000 cycles min.
- Electrical Characteristics
 Contact resistance: 50mΩ typical, 100mΩ max
 Insulation resistance: >1000MΩ/500V DC
- Solderability
 Vapor phase: 215°C, 30sec. Max
 IR reflow: 260°C, 10sec. Max
 Manual soldering: 370°C, 3sec. Max
- Environmental Characteristics
 Operating temperature: -40°C~+85°C
 Operating humidity: 10%~+95%RH
- Package: tray, 40PCS/tray, 2000PCS/ Carton

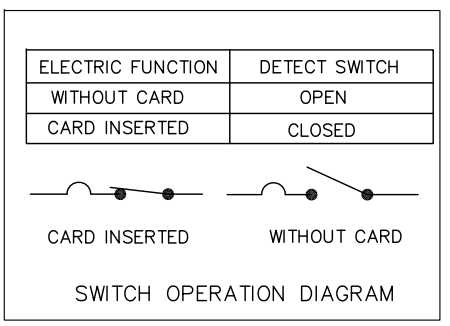

For more information, please help to contact: connmold@foxmail.com Tel.: 18922965797

WWW.CONNMOLD.COM

DIMENSION UNITS	TOLERANCE	PART NAME SMART CARD SOCKET 3.65MM HEIGHT	
MM	X±0.50 .XX±0.25		
	.X±0.35 .XXX±0.15		
DRWN: Robert	Dec. 12, 2020	PART NUMBER	
CHK'D: Yuri	Dec. 12, 2020	CMSIM661018	REVISION
APPR: Linda	Dec. 12, 2020		A
THIRD ANGLE PROJECTION	CUSTOMER P/N	CUSTOMER	SHEET NUMBER
	/	GENERAL MARKET	1 OF 2