

RECOMMENDED PCB LAYOUT (T:1.60mm)
TOLERANCE UNSPECIFIED ±0.10mm

NOTES:

1. MATERIAL:
 - 1.1 Housing: High Temperature Thermoplastic UL94V-0; Color Black.
 - 1.2 Terminal: Copper Alloy.
 - 1.3 Shell: IRON.
2. SPECIALITY:
 - 2.1 Rated current: 0.5A
 - 2.2 Rated voltage: 30V
 - 2.3 Contact Resistance: 30mΩ MAX
 - 2.4 Insulation Resistance: 100MΩ MIN 500V DC
 - 2.5 Dielectric withstanding voltage: 100V AC.
 - 2.6 Solder ability: 255±5°C, 10±0.5s.
 - 2.7 Durability: 10000 Cycles Min.
 - 2.8 Insertion Force: 44.1N MAX
 - 2.9 Withdrawal Force: 9.8N~44.1N
 - 3.0 Operating condition: Temperature -40°C~+85°C; Humidity 80% R.H MAX
3. PACKAGE: TAPE REEL, 480PCS/REEL

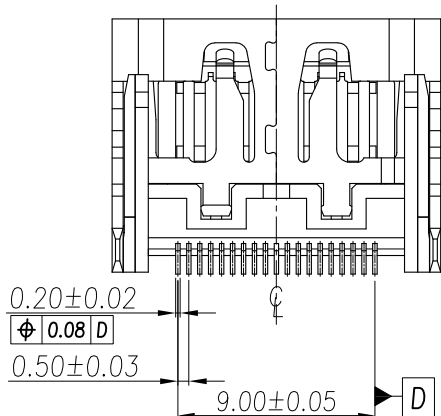

REV	EC No.	DESCRIPTION	Symbol	DATE
A	/	new release	/	Oct. 12, 2021

For more information, please help to contact: connmold@foxmail.com, Tel.: 18922965797

WWW.CONNMOLD.COM		<h1>ConnMold</h1>	
DIMENSION UNITS	TOLERANCE		
MM	X±0.50 .XX±0.25 .X±0.35 .XXX±0.15	PART NAME	HDMI A SMT TYPE 2.20MM IRON SHELL
DRWN: Robert	Oct. 12, 2021	PART NUMBER	CMHMF661005
CHK'D: Yuri	Oct. 12, 2021	REVISION	A
APPR: Linda	Oct. 12, 2021	CUSTOMER	GENERAL MARKET
THIRD ANGLE PROJECTION	CUSTOMER P/N	SHEET NUMBER	1 OF 2
	/		